

8

1

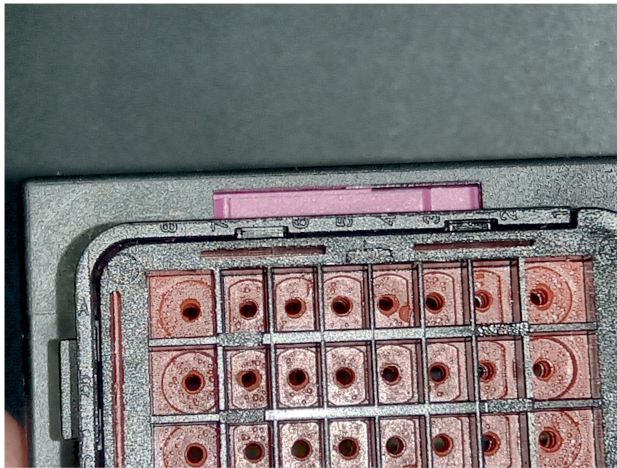

A

B

C

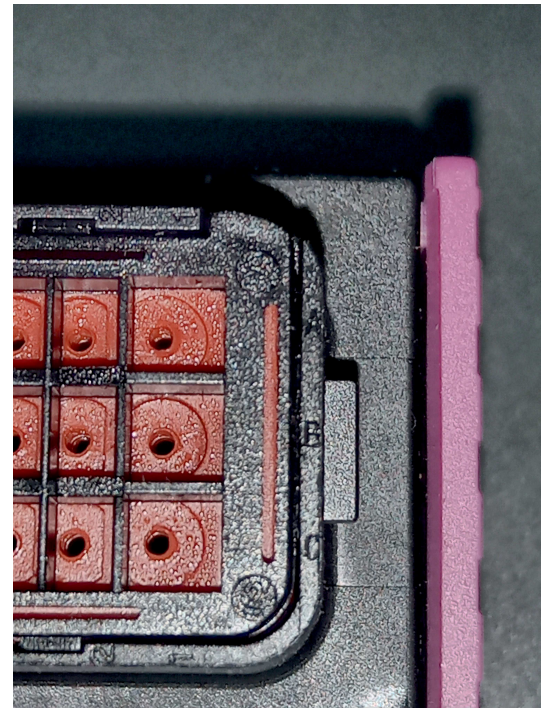

- A1 -
- A2 -
- A3 -
- A4 - OPTO IN
- A5 - CAN HIGH
- A6 - CAN LOW
- A7 - VREF
- A8 - MOTOR OUT A

- B1 -
- B2 -
- B3 - PPS2
- B4 - PPS1
- B5 - TPS2
- B6 - TPS1
- B7 - GND
- B8 - MOTOR OUT B

- C1 -
- C2 - SPARE IN
- C3 - IDLE IN
- C4 - USB D+
- C5 - USB D-
- C6 - USB 5V
- C7 - USB GND
- C8 - +12 VOLT

+12 VOLT : kapcsolt tápfeszültség

GND: test

VREF: referencia feszültség (+5V) szenzorokhoz

TPS1 és TPS2: pillangószelep szenzor jelek

PPS1 és PPS2: pedál szenzor jelek

USB D+, USB D-, USB 5V, USB GND: USB külső csatlakozó kábeléhez

CAN LOW és CAN HIGH: CAN BUS

MOTOR OUT A és B: pillangószelep DC motor 2 kimenete

OPTO IN: fordulatszámjel bemenet (OPTO leválasztóval)

SPARE IN: tartalék analog bemenet

IDLE IN: alapjárat vezérlő bemenet (analóg és pwm)

## Mercedes pedal sensor:



RockAuto.com

B37 Accelerator pedal sensor (with 2 Hall elements)  
 N3/10 ME-SFI control unit  
 SP1M Ground, Hall element for signal 1  
 SP1S Signal 1 (limited to 5 V)  
 SP2M Ground, Hall element for Signal 2  
 SP2S Signal 2 (limited to 2.5 V)  
 USP1 Voltage supply to accelerator pedal sensor 5 V

- 1 - 5 volt
- 2 - 5 volt
- 3 - GND
- 4 - Singal 1
- 5 - Signal 2
- 6 - GND

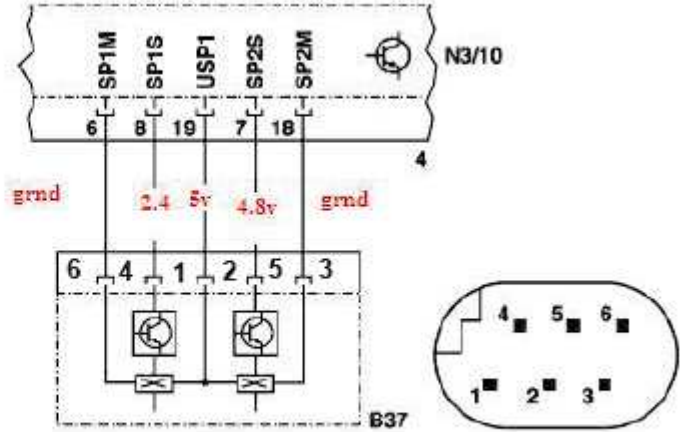

## TOYOTA Pedal Sensor:

P30.20-2033-11

### Wire Harness Side

A13

Accelerator Pedal Position Sensor

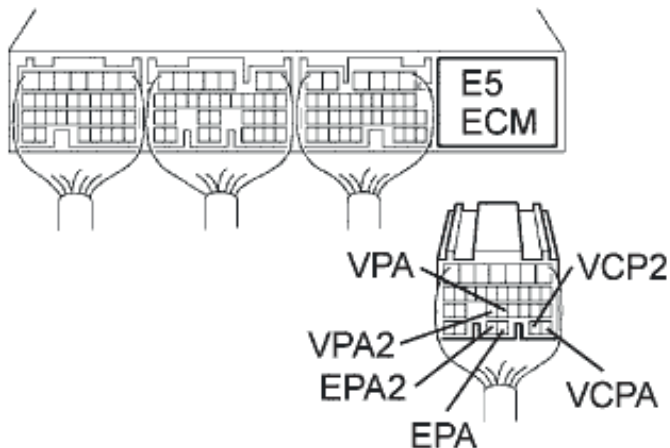
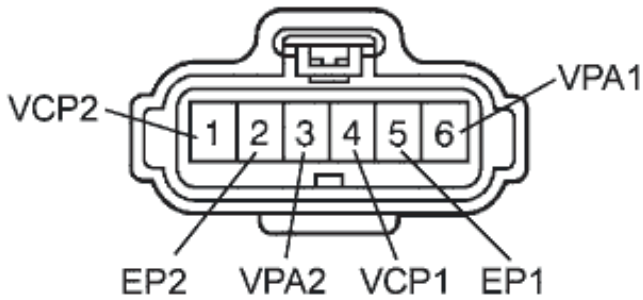

TO: TrailBlazer

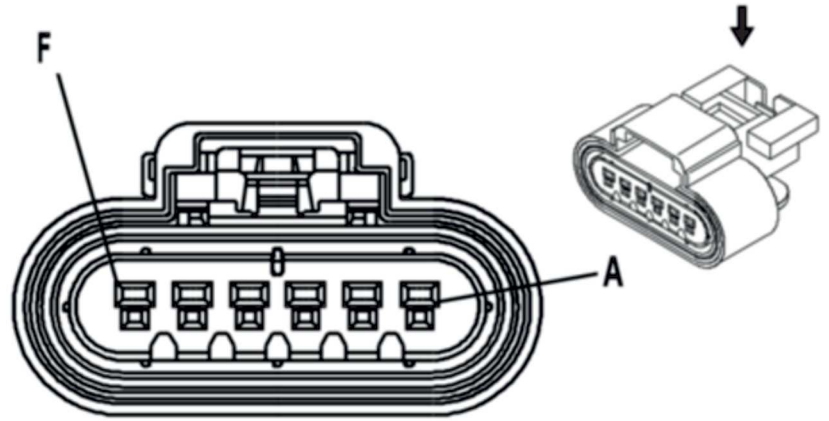

Accelerator Pedal Position (APP) Sensor

Pin	Wire Color	Circuit No.	Function
A	PU	1272	Low Reference
B	L-BU	1162	APP Sensor 2 Signal
C	TN	1274	5-Volt Reference
D	BN	1271	Low Reference
E	D-BU	1161	APP Sensor 1 Signal
F	WH/BK	1164	5-Volt Reference

FROM: Colorado

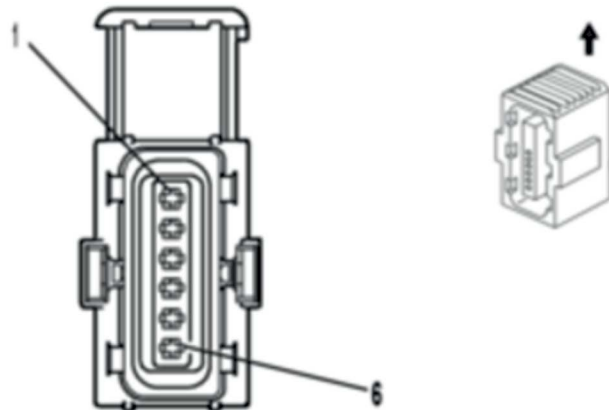

Connector Part Information

- 15383136
- 6-Way F Sealed (BK)

Pin	Wire Color	Circuit No.	Function
1 <b>A</b>	PU	1272	Low Reference
2 <b>F</b>	WH/BK	1164	5-Volt Reference
3 <b>E</b>	D-BU	1161	APP Sensor 1 Signal
4 <b>D</b>	BN	1271	Low Reference
5 <b>C</b>	TN	1274	5-Volt Reference
6 <b>B</b>	L-BU	1162	APP Sensor 2 Signal

## Accelerator Pedal Position (APP) Sensor

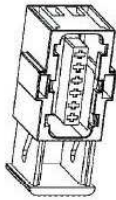
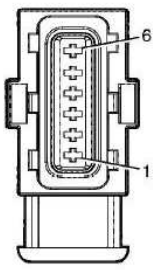

### Connector Part Information

- OEM: 7283-6463-30
- Service: See Catalog
- Description: 6-Way F (BK)

### Terminal Part Information

- Terminal/Tray: 4-964274-1/25
- Core/Insulation Crimp: E/A
- Release Tool/Test Probe: J-38125-560/J-35616-33 (YE)

## Accelerator Pedal Position (APP) Sensor

Pin	Wire Color	Circuit No.	Function
1	0.5 BN/YE	1274	5-Volt Reference
2	0.5 WH/BK	1164	5-Volt Reference
3	0.5 D-BU/WH	1161	APP Sensor 1 Signal
4	0.5 BN	1271	Low Reference
5	0.5 PU	1272	Low Reference
6	0.5 L-BU	1162	APP Sensor 2 Signal

## NISSAN:

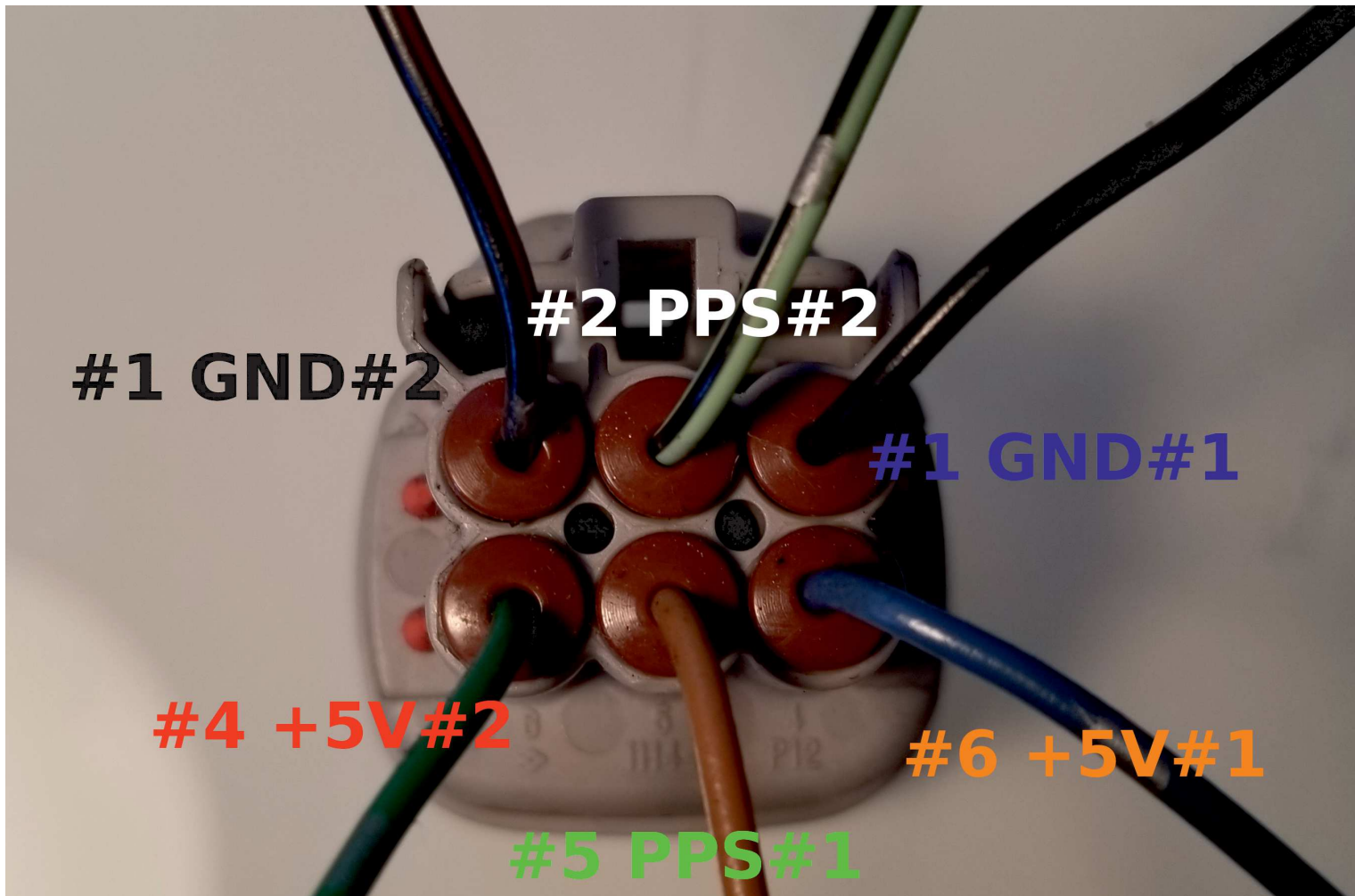

# THROTTLE BODY:

GM: 2005+ LS2 / SSR TB Connector

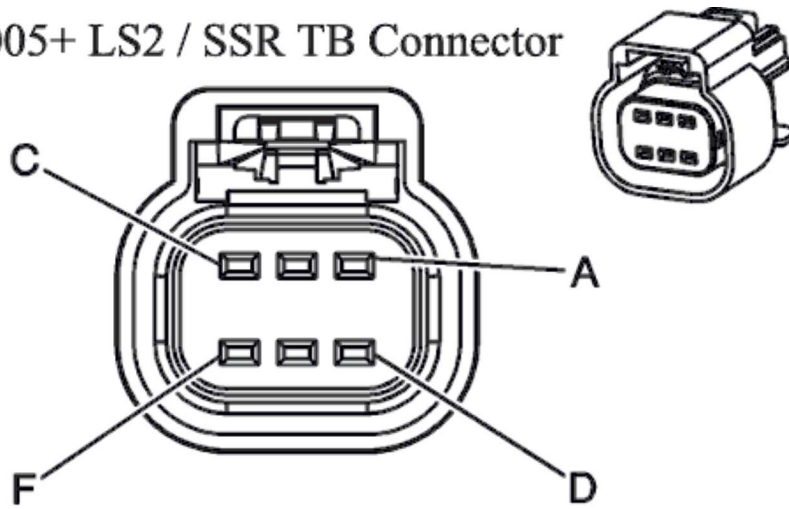

- A - BN - TAC Motor Control 2
- B - YE - TAC Motor Control 1
- C - BK/WH - Low Reference
- D - Dk GN - TP Sensor 1 Signal
- E - L-BU/BK -5-Volt Reference
- F - PU - TP Sensor 2 Signal

VW 1.8t; BMW 330i:

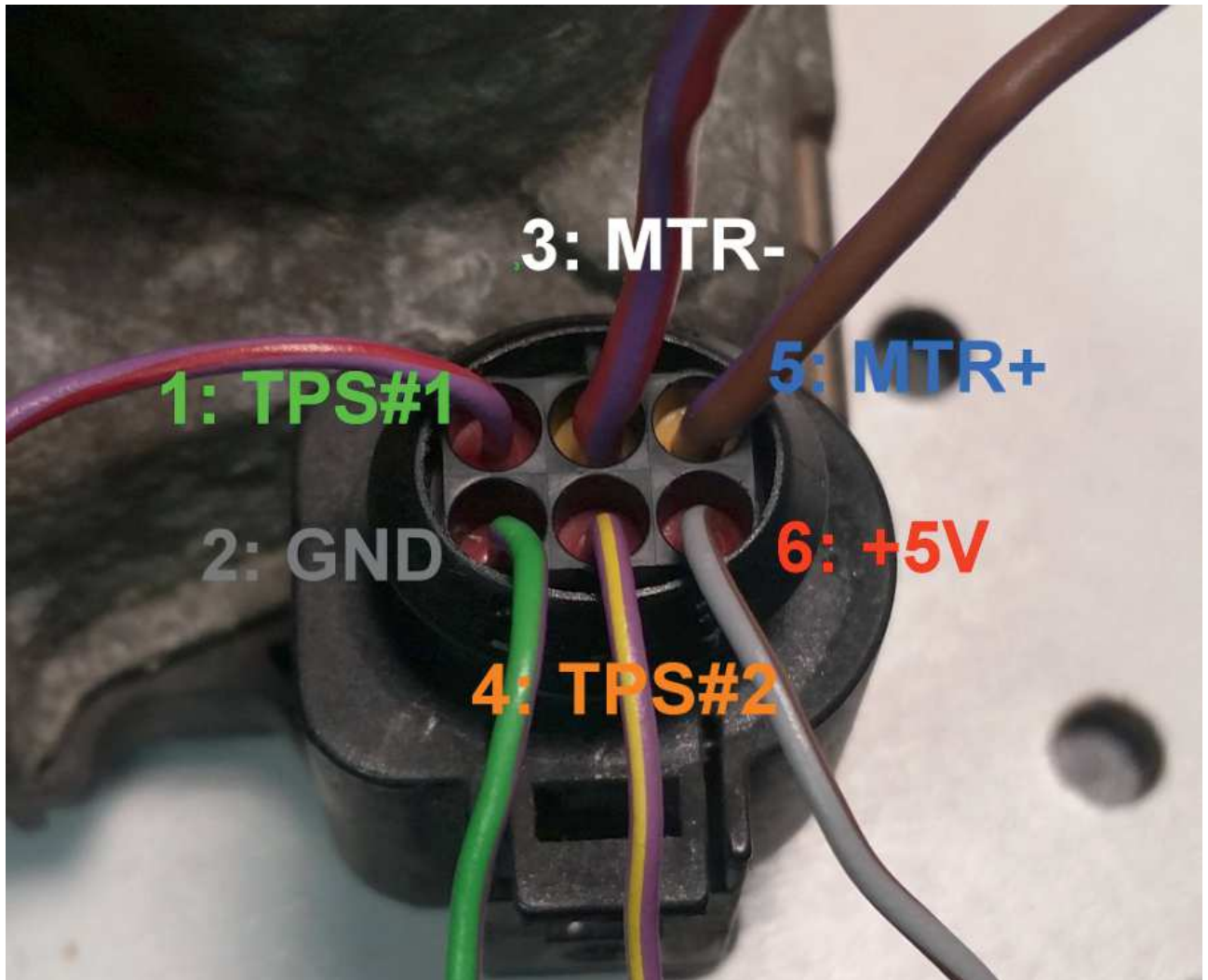

# MERCEDES:

Facing back of connector

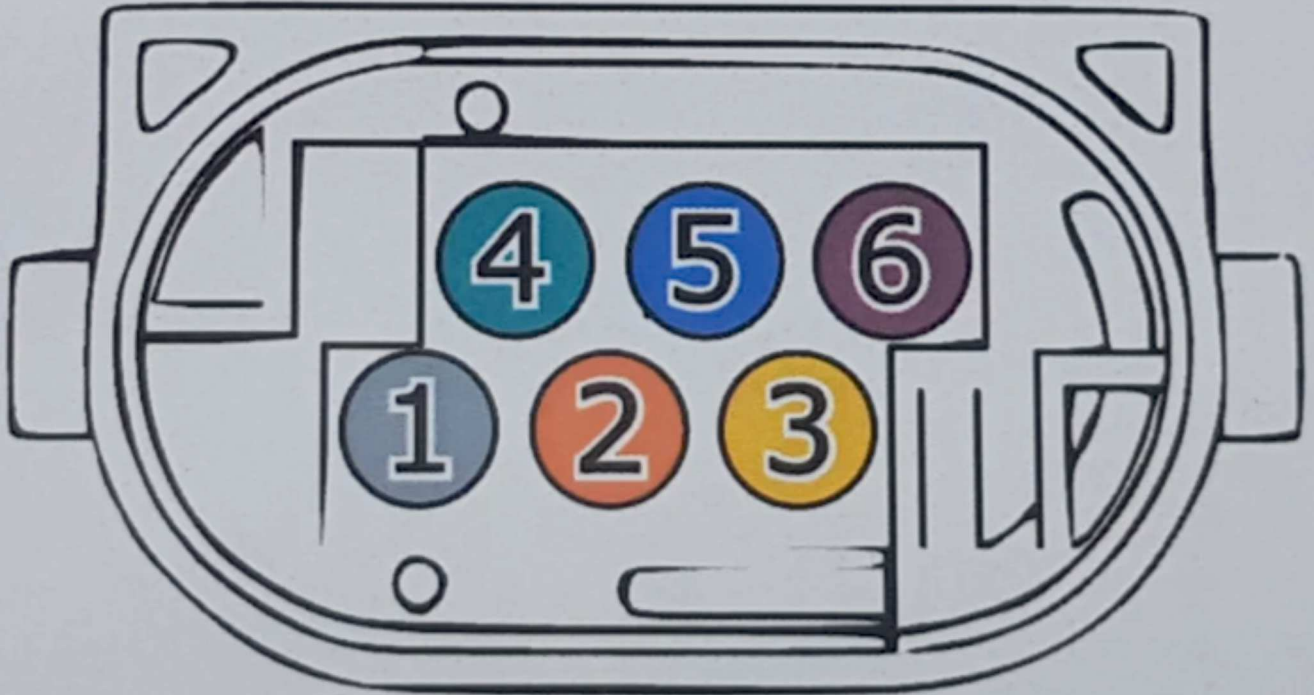

1. DBW Motor (-)
2. TPS Signal Ground (-)
3. TPS Power 5v (+)
4. DBW Motor (+)
5. TPS AV2
6. TPS AV1

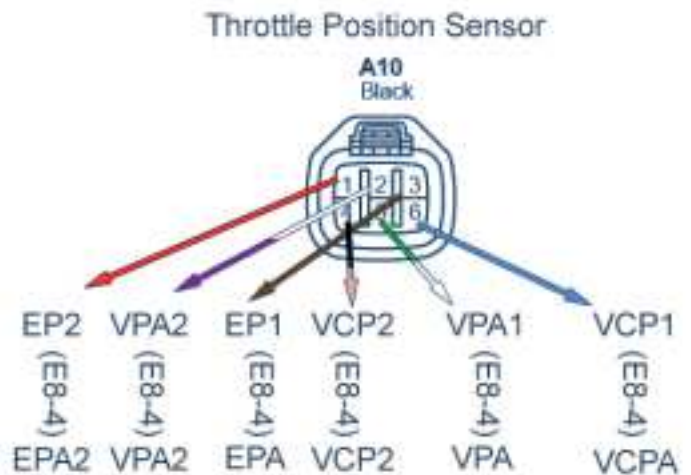
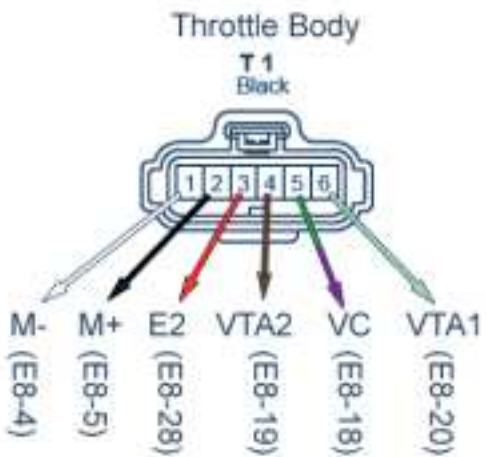

1. Motor-  
2. Motor+

3. E2 Sensor ground  
4. VTA2 TPS Sub

5. Vc 5V  
6. VTA1 TPS Main

NISSAN:

Hitachi SERA576-01 60mm Connector 6189-7761

